

THE PRESERVE AT SHARP MOUNTAIN DESIGN REVIEW MANUAL

Updated 2023

As a mountain estate community, The Preserve at Sharp Mountain, takes great care to ensure that all homes are constructed to conform to cohesive architectural guidelines established by the POA. As such, the POA has formed an Architectural Review Committee (ARC) to review and approve all house plans, modifications, and additions prior to construction to ensure conformance with the established building standards.

The Design Review Manual (DRM) and the Builder's Guideline form guide the ARC to make decisions in the best interest of the community. Further information is also available in the Covenants. Additionally, the Board may jointly be involved in ARC decisions, if needed, to ensure that established community architectural guidelines are being followed (even if not explicitly stated in the DRM).

Plans for any and all future alterations such as, *but not limited to*, painting, additions, renovations, fencing, outdoor kitchens, swimming pools, hot tubs installed in the ground, hardscaping and large landscaping projects, must be submitted to the ARC for approval. Small landscaping and general landscaping maintenance do not require approval. Any project requiring heavy loads of materials and equipment must be approved by the ARC before construction can begin and the homeowner needs to submit a construction deposit along with the modification application prior to beginning the project. A modification application form may be found on The Preserve Website.

NEW CONSTRUCTION AND/OR MODIFICATIONS

NEW CONSTRUCTION: After closing on a lot, and prior to clearing the site, the property owner must submit one set of plans to the ARC. The plans become a permanent record of the ARC review and include the following:

1. A plat of the property with a scaled footprint of the house showing the primary building footprint with all front, rear and side setbacks numerically labeled. Additionally, stand-alone garages (see additional requirements later in the DRM), where proposed, should be located on the plan and must be located to the rear of the house in order to minimize the view of the garage from the street. The orientation of the driveway, from the street to the home site, should also be shown, as well as hardscape such as paved parking areas, walkways, retaining wall(s) as well as a review of such concerns with proper drainage and insuring minimal drainage impact on streets, road shoulders or adjacent lots. Finally, the limits of any areas to be cleared outside the limits of the house and driveway, including yard areas and view corridors, should also be clearly marked with dimensions included as appropriate. The front of the house must also be clearly indicated on the plans.
2. A hard copy of architectural working drawings (preferably size D) showing the floor plans and all exterior elevations. These drawings shall include roof pitches and

- overhangs, room sizes, a/c and heated square footage, total square footage, exterior details such as the front door, window and door trim, shutters, porch railings, pickets, etc.
3. Selections for all exterior features including, but not limited to, base paint, trim paint, shutters, siding, stucco, doors, windows, lighting, garage doors, stone, brick, are to be submitted as actual designated samples of these items.
 4. Landscape plan may be submitted at a later date, prior to, but no later than two weeks before, the installation of any landscape materials.

When the request for a review is received by the ARC, the ARC will refer the prospective owner to online copies of the Builder Guidelines Form and the Design Review Manual (which can be downloaded and copied). Both these documents are referenced at the signature blocks on the last page of the Builder Guidelines. The property owner and the contractor must sign this document, indicating that they have read and will comply with requirements within, and return this signed document with the architectural submittal. The complete plans and samples will be reviewed by the ARC. If accepted, written approval will be given to the property owner within 7 days after the monthly ARC meeting. If the plans are not acceptable, the property owner will be notified, with specific issues cited, within 7 days after the ARC meeting as well. Pickens County will not issue a building permit unless the plans have been approved by the ARC.

ANY APPROVAL IS VALID FOR 90 DAYS

A delay longer than 90 days requires re-approval by the ARC.

Application for Architectural Approval should be sent directly to the current ARC Chair-or to any ARC member. This information can be obtained by referring to the Preserve website or by contacting the ARC chair or any Board Member.

Any changes to the approved plans that are proposed during the construction of the house which affect the exterior appearance or siting of the house must be brought to the ARC for written approval before the modifications are undertaken.

The ARC may grant a variance to an owner for any of the specific requirements listed below, based on specific relative information which justifies the request. In the event of an appeal for a requested variance, the ARC and the Board will confer for a final decision.

Construction activity of any kind shall not commence on the lot until the owner has closed on the lot, received written ARC approval of the plans, and obtained a Pickens County building permit. However, if an owner wants to clear debris/ dead trees or for example, determine location of a future well, they may be allowed to do so if they submit the construction deposit and a signed copy of the Builders Guidelines form in advance.

A member of the ARC may enter the property and construction site from time to time with advance notice and property owner approval to ensure that the construction is adhering to the approved plans.

HOME DESIGN: In construction of homes to be built at The Preserve at Sharp Mountain, the owner must ensure the following minimum key criteria are met:

1. Minimum Square-Footage:

- a) Single Story: 1800 square feet of air-conditioned/ heated living area
- b) Two Story: The minimum first floor air-conditioned/ heated living area must be 1800 square feet

2. Setbacks

The minimum building setbacks are as follows:

- a) Front: 100 feet from the centerline of the street
- b) Side: 25 feet from all side lot lines
- c) Side street: 100 feet from the centerline of the street
- d) Rear: 50 feet from the rear property line
- e) The setback from a warm water stream is 25 feet from the top of bank and 50 feet from a cold water or trout stream. No disturbance of any kind is permitted within this setback area. (This is in accordance with County and state zoning requirements)

3. Slab Houses

Unless otherwise approved by the ARC, all slab houses must be poured concrete slab on grade with a minimum of one step up from finished walkway to interior floor elevation. The exterior of the foundation, porch footers, and/or slab extensions, where visible from streets and/or common areas, shall be veneered with brick, stone or stucco depending upon the exterior material of the main house.

4. Foundations

All houses constructed with a basement or crawl space must have brick, stone, or stucco veneered foundations, as applicable to the material of the main house, including chimney stacks, when visible from streets and/or common areas. All foundations shall be constructed of poured reinforced concrete; all front stoops or porches shall be supported by stoop arms or continuous foundation walls and completely veneered with brick or stone, depending on the type of home being built. There shall be no exposed space under any front facing stoop or porch that would exceed 2 feet.

5. Brick Homes

All brick shall be in subdued, earth tone colors. Old brick will be accepted in special areas, as well as the painting of the brick. No weeping or black mortar is allowed. Raised banded stucco trim, in conjunction with brick or additional brick detailing is permitted.

6. Stucco Houses

Stucco houses are permitted with a significant amount of trim, raised banding and detail provided on all four elevations. All stucco shall be in subdued, earth tone colors and submitted for approval.

7. Siding Houses

All siding houses must have brick, stone or stucco veneer on foundation or basement walls up to the first floor level, when foundation or basement walls are visible from streets and/or common areas. Siding shall include details with bottom skirt board, double-sided corner boards, etc. Siding must be one of the following:

- a. Natural wood lap siding/ log homes; hard board lap siding
- b. Natural cedar shakes or shingles
- c. Cementous fiber panels such as hardie plank siding
- d. Vinyl and aluminum siding are strictly prohibited.

8. Stone

All stone shall be in subdued, earth tone colors. Mortar color must be approved. Stone must terminate on an interior corner on front elevations or at logical vertical trim which balances application.

9. Elevations/Colors

The construction of homes with identical elevations in the Preserve is not allowed. Similarly, color schemes side-by-side or across the street from one another are also strictly prohibited. Exterior colors shall be subdued earth tones and samples must be approved. (White is not considered an earth-tone color). Actual samples of all exterior materials are required for review, including, but not limited to, paint or stain colors, roof material, stone and brick. The color of the house should blend with the environment. It cannot stand out.

10. Height

Homes shall be no more than three stories high with a maximum height of 35 feet from the street facing grade at the median point where foundation meets finished grade of soil. The home may include a sub-basement where necessary on steep lots.

11. Roofs, Chimneys, Bays

Roofs shall be dimensional asphalt shingles, cedar shake, slate, raised-seam factory finished metal, or architectural steel factory finished with a minimum pitch of 10/12 on gables and 9/12 front to back. Porch shed roofs with a lesser pitch (typically at least 5/12) may be approved at the discretion of the ARC. Tile roofs and flat roofs are strictly prohibited. Silver metal roofs are strictly prohibited. All plumbing stacks shall be painted black. All chimneys on the front of homes must be carried to the ground and match siding color. All chimney tops, whether brick, stucco or siding, must be topped with a metal shroud painted black. No plumbing or heating vents should penetrate roof surfaces which face streets or common areas.

12. Garages

All homes must have a minimum two-car garage. The garage door shall be painted or stained to blend in with the exterior of the house. Side entry garages are preferred unless the builder can demonstrate the lot does not accommodate a side entry garage. If not attached to the house, the garage should be connected to the house via a breezeway. Stand-alone garages are allowed, but must be of sufficient size and detailing including windows on at least two sides to warrant not being attached to the main body of the house. The garage must be constructed of similar materials and colors as the main house, and meet the same roof pitch requirements. Front facing garage openings must have one garage door per garage bay.

13. Retaining Walls

All retaining walls visible from any street or common area must be veneered with the same masonry material that is on the house foundation. Retaining walls on the rear may be pressure treated timbers or architectural block.

14. Driveways and Sidewalks

All driveways must be hard surface from the edge of the roadway to the home if that distance is less than 100 ft., or to the following, whichever is greater:

1. 100 feet from the edge of the roadway OR
2. To a point where the driveway can no longer be seen from the roadway in winter with trees free of leaves OR
3. To a point where the driveway no longer drains toward the roadway.

Design and grading for driveway must take into consideration proper drainage and potential erosion of common areas. Ensure that water is carried away from the roadbed, paving, and shoulders into ditches and does not erode the shoulder of the ditches.

The hard surface portion of the driveway must be concrete, asphalt or brick-pavers. The driveway should be curvilinear in nature to the extent that site allows. All sidewalks must be

either concrete or a combination of concrete and stone or concrete and brick; in either case matching the materials specified for the balance of the home. Inlaid brick or stone including pressed concrete pavers will be allowed subject to approval by the ARC. Paving of driveway must be complete prior to the return of escrow or bond monies.

15. Windows and Doors

Silver-finish aluminum doors (including sliding doors) and windows are strictly prohibited. A factory finished or anodized aluminum finish may be used, the color of which shall be specified in the plans submitted to the ARC for approval. All windows on the front of the house must have some level of architectural detail, i.e., molding, banding, or brickwork along the top. Painted front doors must match or compliment shutter/color accent; if leaded glass unit is used, it must be free of color.

16. Landscaping

The initial landscape plan must be submitted and approved prior to installation of the landscape material. The plan shall indicate the size and location of all trees, shrubs, grass, etc. to be planted on the property. All disturbed areas on the lot must be stabilized and covered for erosion control. No plantings will be allowed which interfere with clear visual field required for safe vehicular activity in streets and at intersection of street and driveway. If plantings are near the street, they must be kept at a reasonable size in the future as well, so as to allow clear visual field for vehicular activities. Subsequent landscaping after initial construction which requires major work will require a modification approval. Small landscape updates and/or maintenance does not require prior approval.

17. Pools

Plans for swimming pools, hot tubs, decks, patio screening, etc. must be approved by the ARC. Screened pool enclosures should not extend beyond the side of the house and should be either painted or stained wood supported or dark metal. Above-ground pools are strictly prohibited. Pool enclosure plans and siting must be reviewed and approved by ARC.

18. Antennae

Exterior television or radio antennae or satellite dish or receiver of any sort shall be placed where least visible from streets or common areas. Review materials submitted should include proposed location of satellite dishes.

19. Mailboxes

All mailboxes must be a black, standard U.S. Postal Office mailbox. All mailboxes must be mounted on the standard Preserve at Sharp Mountain post and installed in accordance with the detail in the appendix of this manual. All signs must match the neighborhood standard for signs.

The sign needs to be made out of wood/sturdy weather resistant composite material that is 1.50 – 1.75 inches thick. Additionally, the letters, numbers, and logo need to be sandblasted, etched or engraved to provide at least 0.5-inch relief. (See diagram on Page 11 of DRM.) Signs not meeting the specifications will be removed at the homeowner's expense and replaced with one that does meet the requirements. It is suggested that the homeowner get ARC approval prior to going with a vendor that has not already been vetted by the ARC. The owner is responsible for the purchase and installation of the mailbox, post, and address sign. Mailbox posts are to be left unstained or stained in natural, neutral brown tones. (Stain color must be submitted to the ARC for approval.)

20. Basketball Backboards

Basketball backboards are acceptable. The backboard should be located, whenever possible, such that it is not visible from streets or common areas. If this is not possible, then the basketball backboard must be mounted inconspicuously perpendicular to the street and should be painted to match the house.

21. Deck and Porch Posts

Deck and Porch posts may be wood or metal and must be 6" x 6" in size or greater and stained or painted to match the deck. Round metal pipe columns will be allowed to support decks and porches where grade conditions require. If round metal pipe columns for porch or deck are visible from streets or common areas or adjacent lots, the owner will be required to wrap round metal pipe columns with wood, cementous siding, brick or stone.

22. Prefabricated Structure

Prefabricated structures or factory-built structures shall not be permitted within the community and such manufactured units shall not be employed as elements in the construction of residential structures affixed to real property except by express written consent of the ARC. Mobile homes or trailers used as construction offices or temporary living quarters are strictly prohibited.

23. Fences and Walls

The approved fence design for The Preserve at Sharp Mountain is a natural cedar split-rail fence or equestrian fence with a minimum of 3 rails and a maximum height of 5 feet. The location of the fence must be approved by the ARC. If wire is to be added to the fence, it must be inside the fence (toward the house) and the color of the wire must be approved by the ARC. Block walls and shadowbox fence shall not be installed except by express written consent of the ARC. Guard rail design to be reviewed and approved by ARC. **In no event shall chain link fencing be permitted.**

24. Propane Tanks.

Propane tanks shall be buried or otherwise not visible from adjacent lots or common area, including streets. If the lot makes the burial of a propane tank impossible, the installation and location of any above ground propane tank must be approved by the ARC.

25. Irrigation System.

Owner installed irrigation systems must only draw from the property owner's well and not from any lake, pond or stream within the Preserve.

27. Signs

During construction, no sign of any kind shall be erected by an owner, other than the construction permit sign, without the prior written consent of the ARC, except that the primary builder may erect one professional sign no more than 14 days in advance of the beginning of construction period and said sign must be removed no later than 14 days after construction is completed.

No other contractor or subcontractor signs are allowed, including signs for remodeling and/or repair work.

28. Construction Deposit (Escrow)

To ensure compliance by owners and builders with the provisions of this Design Review Manual and to protect the improvements within The Preserve at Sharp Mountain, a deposit in the amount of \$4,000.00 ("Construction Escrow") shall be paid to The Preserve at Sharp Mountain Association, Inc. upon submission for approval of plans to the ARC. No construction may commence upon the home site until the Construction Escrow is paid. The owner of the lot shall pay the Construction Escrow.

The Construction Escrow will be held in a non-interest bearing account until the builder/owner has completed construction of the approved improvements on the home site, obtained a certificate of occupancy, and submitted a request for inspection. After a satisfactory inspection, the owner will be issued a refund of either the entire amount if it remains intact, or the balance remaining after any damage or violation costs have been withdrawn.

Authorized Signage



THE PRESERVE AT SHARP MOUNTAIN
STANDARD MAILBOX

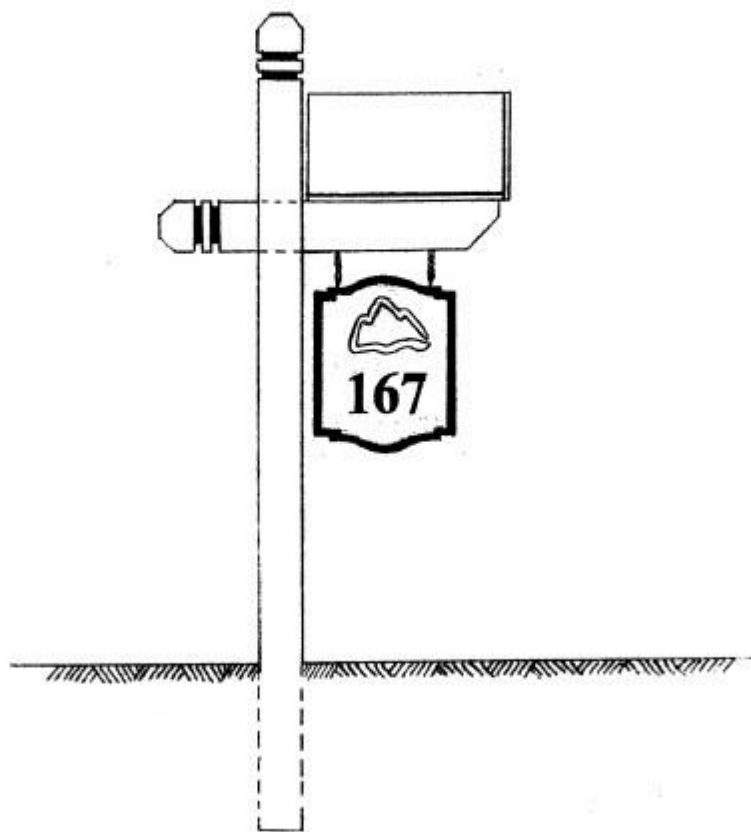

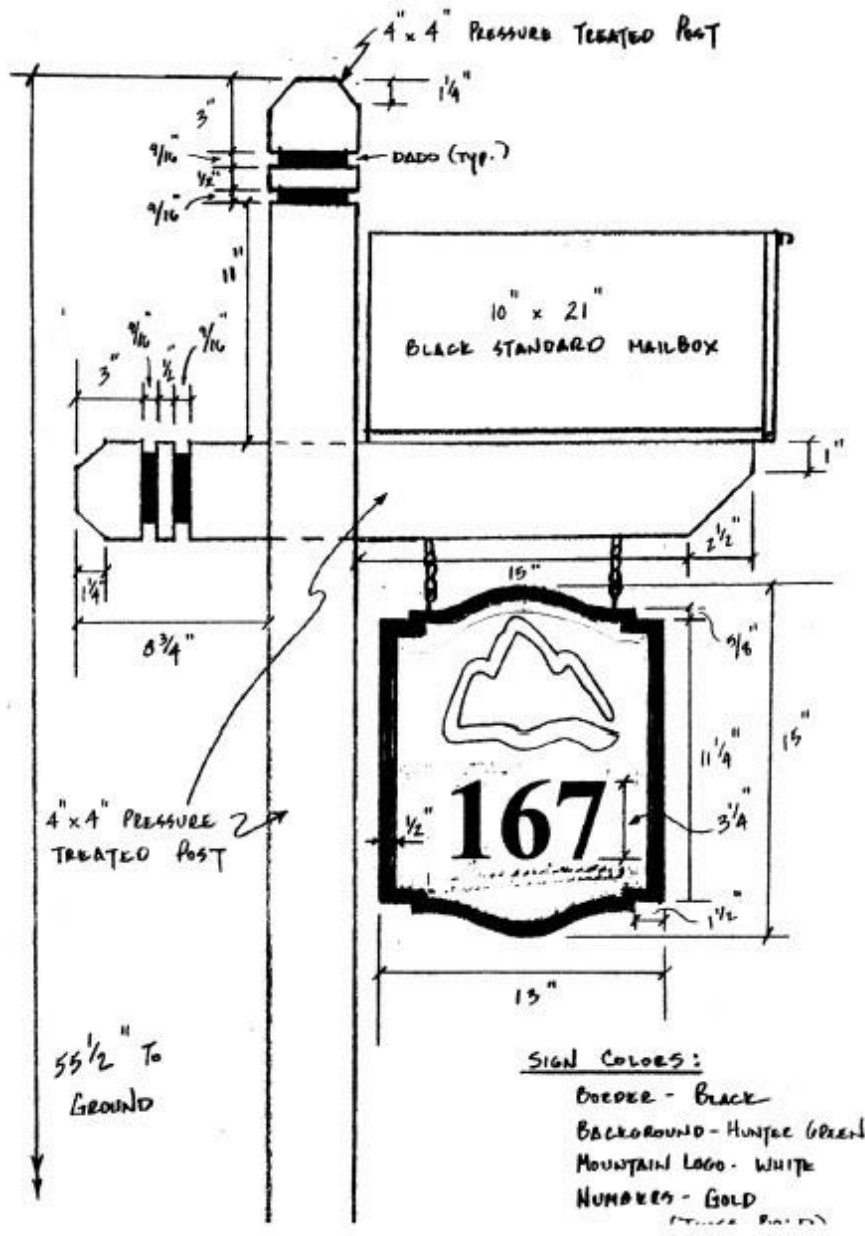

Approved colors for mailbox address sign.



Roads/ Grounds Committee use Krylon Gloss Hunter Green Spray Paint for deep green color.